

ez

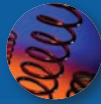

automotive



industrial



wood

# EZ MODIFIED DOWNDRAFT BOOTHS

- EZ TO INSTALL
- EZ TO OPERATE
- EZ TO MAINTAIN
- EZ TO PRESSURIZE
- EZ TO QUICK SHIP

The Col-Met EZ Modified Downdraft Booth intakes fresh air from the cleaner upper levels of the shop through a filter bank located in the booth ceiling near the product doors. The filtered air is drawn down through the booth to an exhaust filter system at the other end. This booth is equipped with a pre-filter plenum for additional intake air filtration.

The basic modified downdraft design allows for easy pressurization with the addition of an intake fan or a heated air make up unit.

### LIGHTING FEATURES

Bright full booth illumination is provided by ten four-tube, 48", 32-watt, fluorescent light fixtures in the angled ceiling panels and side walls. Each is sealed behind clear tempered safety glass. All fixtures are UL listed and approved for their intended use and placement.



OPTIONAL AMU AND TRIFOLD DOORS WITH POWDER COATED WHITE



OPTIONAL POWDER COAT WHITE

[www.paintbooth.com](http://www.paintbooth.com)

1-800-637-4027

## CONSTRUCTION FEATURES AND QUALITY STANDARDS

- Booths are constructed from 18 gauge, prime-quality galvanized steel
- All panels and support members are precision punched for easy nut and bolt assembly
- Quality brand-name tubeaxial fans and ODP motors
- 5/16" inch bolts with self locking nuts
- Industry-leading light levels
- Spray booth specific, dual voltage T-8 32-watt light fixtures
- Booths include installation instructions, fan, motor & drive, fasteners, hardware, and sealant necessary for assembly
- Control panel and other electric components can be purchased separately
- ETL listed when optional control panel is added
- Personnel access doors are pre-hung in a heavy gauge galvanized steel frame for easy installation
- Product doors are field hung to facilitate installation on uneven floors
- Brixon™ latches are provided for each door opening

COL-MET SPRAY BOOTHS COMPLY WITH ALL APPLICABLE OSHA AND NFPA REGULATIONS.



OPTIONAL CONTROL PANEL



# EZ MODIFIED DOWNDRAFT BOOTHS

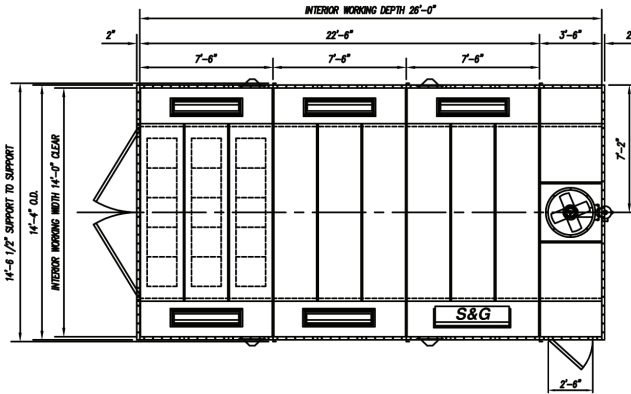

PLAN VIEW

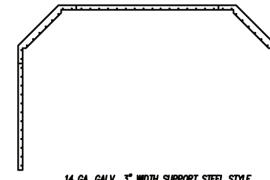

14 GA. GALV., 3" WIDTH SUPPORT STEEL STYLE

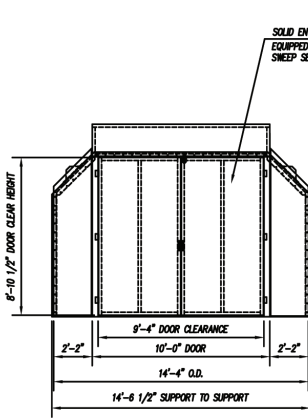

END VIEW FROM BAY END

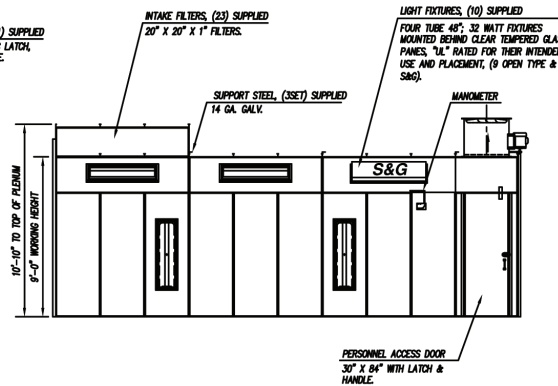

BOOTH SIDE VIEW

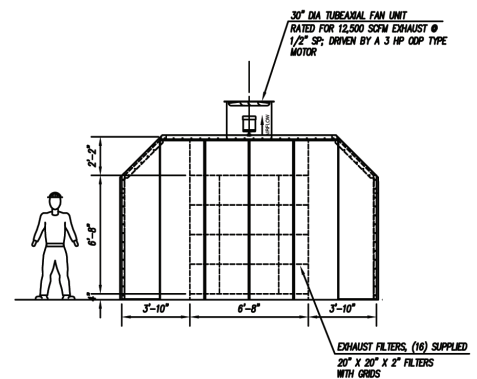

END VIEW @ CHAMBER

Model Number	Interior Dimensions			Exterior Dimensions			Access Doors	Nominal Door Opening				Lights		Air Flow SCFM	Fan Spec.		Filters	
	Width	Height	Length	Width	Height	Length		Width	Height	Qty	Type	Open	S&G		Dia.	HP	Int.	Exh.
EMD26SB	14'-0"	9'-0"	26'-0"	14'-6 1/2"	10'-10"	26'-4"	1	9'-4"	8'-10 1/2"	1	Solid	9	1	12,600	30"	3HP	23	16
EMD26PSB	14'-0"	9'-0"	26'-0"	14'-6 1/2"	10'-10"	26'-4"	1	9'-4"	8'-10 1/2"	1	Solid	9	1	12,600	30"	3HP	15	16

[www.paintbooth.com](http://www.paintbooth.com)

1-800-637-4027

1/10 42EN



Optional powder coat finish shown.