



LP2 3-AXIS MAST LIFTS

Man Lifts for Prep, Paint, Wash, and Fabrication

With 30+ years experience, LPI is the recognized industry leader in manufacturing lifts. Challenge us with your application.



3-Axis Man Lifts

- Enhance productivity
- Ergonomic for operators
- Pneumatically powered
- Hazardous environments
- Paint booths
- Wash booths
- Manufacturing processes
- Welding, assembly or loading bays

Lifts can be designed to fit your specific application.



www.lpi-inc.com

LP2 3-AXIS MAST LIFTS

Lift Systems for Prep, Paint, Wash, and Fabrication

- Raised platform heights up to 22ft.
- Retracted dimension of 3ft.
- Extended dimension of 9.5ft.
- Operator platform capacity 500lbs.
- Pneumatic/mechanical power unit
- Includes in-line Filter/Regulator/Lubricator
- Standard platform 48in. wide x 21in. deep
- Operator controls on front rail of platform
 - Hand controls for Y-Axis, Z-Axis, and emergency stop
 - Foot control for X-Axis
- Base control to raise and lower platform

- Auxiliary air connection in platform
- Self-closing/self-latching entry gates
- 1 and 2 axis models available
- Lift requires a clean, dry air supply of 80 scfm @ 100psi with a 40°F dew point
- Rail guided travel (X-Axis)

Travel Speeds:

- X-Axis variable up to 40ft./min
- Y-Axis 15.0 ft./min.
- Z-Axis 15.0 ft./min.

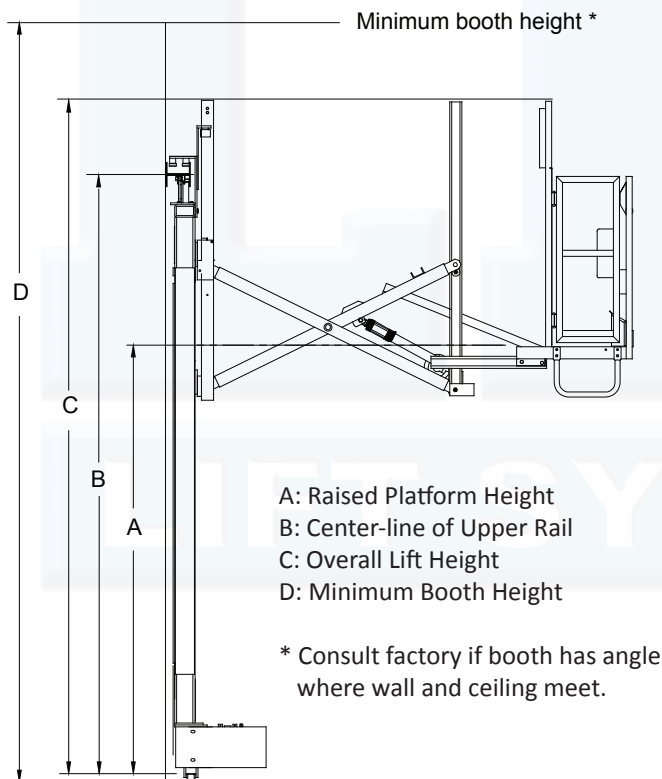

Model LP2 Fully Extended Dimension 9ft.-7in.				
Model	A	B	C	D
LP2-610	6.0	9.3	11.5	12.0
LP2-710	7.0	10.3	12.5	13.0
LP2-810	8.0	11.3	13.5	14.0
LP2-910	9.0	12.3	14.5	15.0
LP2-1010	10.0	13.3	15.5	16.0
LP2-1110	11.0	14.3	16.5	17.0
LP2-1210	12.0	15.3	17.5	18.0
LP2-1310	13.0	16.3	18.5	19.0
LP2-1410	14.0	17.3	19.5	20.0
LP2-1510	15.0	18.3	20.5	21.0
LP2-1610	16.0	19.3	21.5	22.0
LP2-1710	17.0	20.3	22.5	23.0
LP2-1810	18.0	21.3	23.5	24.0
LP2-1910	19.0	22.3	24.5	25.0
LP2-2010	20.0	23.3	25.5	26.0
LP2-2110	21.0	24.3	26.5	27.0
LP2-2210	22.0	25.3	27.5	28.0

All measurements rounded to nearest foot.

Challenge us with your application!