



LP2 3-AXIS MAST LIFTS

Man Lifts for Prep, Paint, Wash, and Fabrication

With 30+ years experience, LPI is the recognized industry leader in manufacturing lifts. Challenge us with your application.



3-Axis Man Lifts

- Enhance productivity
- Ergonomic for operators
- Pneumatically powered
- Hazardous environments
- Paint booths
- Wash booths
- Manufacturing processes
- Welding, assembly or loading bays

Lifts can be designed to fit your specific application.



www.lpi-inc.com

LP2 3-AXIS MAST LIFTS

Lift Systems for Prep, Paint, Wash, and Fabrication

- Raised platform heights up to 6.7m
- Retracted dimension of 0.9m
- Extended dimension of 2.9m
- Operator platform capacity 227kg
- Pneumatic/mechanical power unit
- Includes in-line Filter/Regulator/Lubricator
- Standard platform 1.2m wide x .5m deep
- Operator controls on front rail of platform
 - Hand controls for Y-Axis, Z-Axis, and emergency stop
 - Foot control for X-Axis
- Base control to raise and lower platform

- Auxiliary air connection in platform
- Self-closing/self-latching entry gates
- 1 and 2 axis models available
- Lift requires a clean, dry air supply of 2.7 cpm @ 6.9 bars with a 4.4°C dew point
- Rail guided travel (X-Axis)

Travel Speeds:

- X-Axis variable up to 12 mpm
- Y-Axis 4.5 mpm
- Z-Axis 4.5 mpm

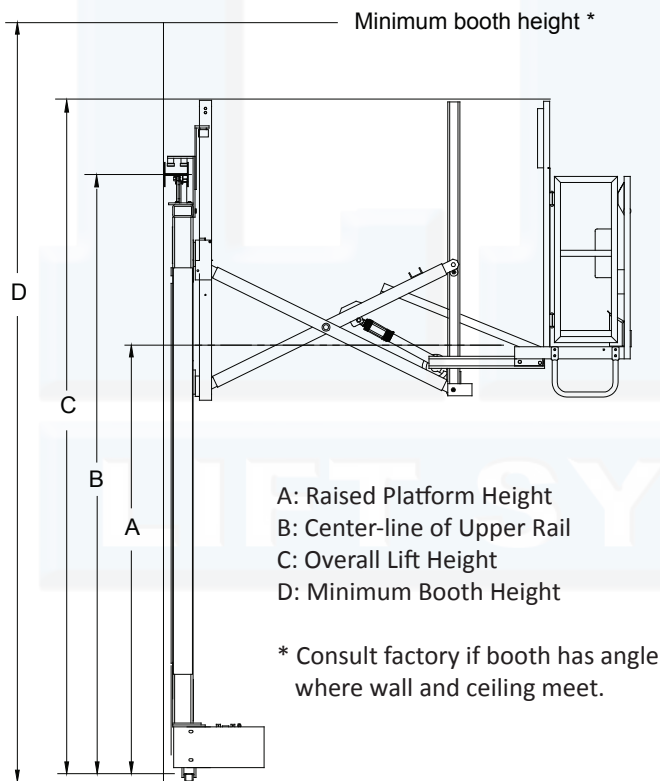

Model LP2 Fully Extended Dimension 2.9m				
Model	A	B	C	D
LP2-610	1.8	2.8	3.5	3.7
LP2-710	2.1	3.1	3.8	4
LP2-810	2.4	3.4	4.1	4.3
LP2-910	2.7	3.7	4.4	4.6
LP2-1010	3	4	4.7	4.9
LP2-1110	3.4	4.4	5	5.2
LP2-1210	3.7	4.7	5.3	5.5
LP2-1310	4	5	5.6	5.8
LP2-1410	4.3	5.3	5.9	6.1
LP2-1510	4.6	5.6	6.2	6.4
LP2-1610	4.9	5.9	6.6	6.7
LP2-1710	5.2	6.2	6.9	7
LP2-1810	5.5	6.5	7.2	7.3
LP2-1910	5.8	6.8	7.5	7.6
LP2-2010	6.1	7.1	7.8	7.9
LP2-2110	6.4	7.4	8.1	8.2
LP2-2210	6.7	7.7	8.4	8.5

All measurements rounded to nearest meter.

Challenge us with your application!