



# Scissor Lifts & Work Platforms for Industrial Applications



# TABLE OF CONTENTS

	<u>Pg.</u>
Scissor Lifts & Work Platforms Defined .....	1
Stationary Scissor Lifts (Model LPSM) .....	2
Manually Positioned Scissor Lifts (Model LPSMT) .....	3
Rail Guided Lift Systems (Model LPST) .....	4
Rail Guided Lift Systems (Model TK) .....	5
Installation Kits for LPST & TK Models .....	6
Work/Catch Platforms (Model LPSPH) .....	7
Work Platform (Model BOOST®) .....	8,9
Standard & Custom Lift Options .....	10
Applications & Industries .....	11

## **ADDITIONAL PRODUCTS & SERVICES**

Other LPI Products .....	12
Custom Lift Solutions .....	12
Warranty, Service & Maintenance .....	13

## **ABOUT LPI, INC**

LPI, Inc. (LPI Lift Systems) is a manufacturer of both standard and custom designed personnel lifts and work platforms. For over 40 years LPI has provided engineering and manufacturing expertise to its customers for processes and applications in hazardous locations, assembly and general industrial areas where elevating personnel or products is needed.

LPI's products help to promote a safer, more ergonomic, work environment which enhances worker productivity and helps reduce work-related injuries or accidents.

LPI Lift Equipment is designed and manufactured in Eau Claire, WI - USA, by LPI, Inc., and meets or exceeds applicable ANSI requirements based on original configuration as manufactured for the intended applications.

LPI reserves the right to make specifications and/or equipment changes without prior notification.

To watch videos of lift solutions LPI has designed & manufactured, visit our YouTube channel at: <https://www.youtube.com/user/LPIncLiftSystems>



**Challenge us with your application!**  
**[www.lpi-inc.com](http://www.lpi-inc.com)**

## SCISSOR LIFTS & WORK PLATFORMS

Scissor lifts and work platforms vary in size offering a safer, more ergonomic positioning solution for workers. Lift designs fall into several design categories varying in axis movement and fall into one of the following groups:

**Stationary:** Anchored in place for movement of people and material up and down

**Manually Positioned:** Typically on caster wheels allowing worker to reposition as needed to access products

**Linear Track/Rail Guided:** Provides access along a fixed position product or line

## PRODUCT DEFINITIONS



### LPSM (page 2)

Stationary mounted and used to elevate personnel in a fixed location. This model lift provides an economical access solution in all areas of your manufacturing process and facility.



### LPSMT (page 3)

Manually positioned and easily moved around by one person. Similar in design to the LPSM lifts, these versatile systems offer a cost effective solution where process areas are not in a fixed location or product size and configuration vary.



### LPST (page 4)

Rail guided and self propelled. This system utilizes a guide rail for positioning workers in applications where the work task is being performed along a linear path. These units can be modified to accommodate process lines and other equipment to increase worker productivity.



### TK (page 5)

Rail guided, self propelled scissor lift that travels along a guide rail in a fixed path. With a higher weight capacity and a larger operator platform, this lift system offers a more versatile range of options. Units can be fitted with explosion proof lighting and hose reels, and are ideal for applications ranging from maintenance pits to welding areas.



### LPSPH (page 7)

Known as a Work/Catch Platform, a high capacity, manually positioned, expandable work platform that can be configured for a variety of applications. Units are easily modified to fit work processes ranging from manufacturing and assembly areas to welding and paint process areas.



### BOOST® (page 8,9)

Single operator, pneumatically powered vertical mast work platform. Platform is drivable and steerable via operator controls. Several options are available to suit various work environments and applications. Ideal for hazardous locations or applications such as paint, powder or welding.

# Stationary Scissor Lifts LPSM

Stationary Scissor Lifts (LPSM) for use in paint/powder booths and other hazardous or non-hazardous locations. These standard scissor lifts can be customized with options to fit specific processes or applications.

## GENERAL INFO

- Raised platform heights: 4'-1" to 11'-8"
- Minimum lowered platform height: 11"
- Operator Platform Capacity: 500 lbs.
- Platform Dimensions: 66"L x 30"W
- 43.5" high guard rail with self-closing gate
- Pneumatic/Hydraulic power for hazardous areas
- Electric/Hydraulic power for non-hazardous areas
- Filter/Regulator/Lubricator (pneumatic option only)
- Quick and easy connection to air source

## CONTROLS / CONNECTIONS

- Primary air source connection: 1/2" NPT
- Auxiliary uncoiled air connection in platform: 3/8" NPT
- Lift requires a clean, dry air supply (50 scfm @ 90 psi with a 40°F dew point)
- Fixed hand control with E-Stop
- Base control to raise and lower platform
- Optional pendant foot control to raise/lower platform

## TRAVEL SPEEDS

- Z-Axis (up/down): 15 fpm

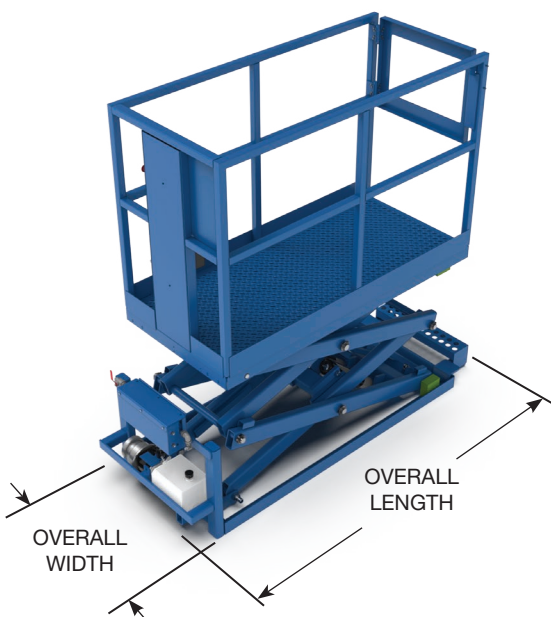

Model LPSM (Stationary Scissor Lifts)					
Model	Raised Floor Ht.	Lowered Floor Ht.	Max Work Ht.	Overall Length	Overall Width
LPSM-48	4'-1"	11"	10'-1"	6'-11"	2'-6"
LPSM-96	7'-8"	1'-4"	13'-8"		
LPSM-144	11'-8"	1'-6"	17'-8"		

-For use on hard, flat and level surface  
 -All LPSM units must be securely fastened to the floor  
 -Designed in accordance with applicable ANSI requirements based on machine configuration as originally manufactured for intended applications



Dimensions shown are nominal. Actual dimensions may vary and are presented with engineering drawings.

Due to continuous product improvement, LPI, Inc. reserves the right to make equipment/specification changes without prior notification.

# Manually Positioned Scissor Lifts LPSMT

Manually Positioned Scissor Lifts (LPSMT) for use in paint process booths and other hazardous or non-hazardous locations. These standard scissor lifts can be customized with options to fit specific processes or applications.

## GENERAL INFO

- Raised platform height: 4'-4" to 11'-11"
- Minimum lowered platform height: 13.5"
- Operator Platform Capacity: 500 lbs.
- Platform Dimensions: 66"L x 30"W
- 43.5" high guard rail with self-closing gate
- Pneumatic/Hydraulic power for hazardous areas
- Electric/Hydraulic power for non-hazardous areas
- Filter/Regulator/Lubricator (pneumatic option only)
- Quick and easy connection to air source
- Transport Handle Kit includes
  - Retractable, pivoting T-handle
  - 6" rigid caster wheels

## CONTROLS / CONNECTIONS

- Primary air source connection: 1/2" NPT
- Auxiliary uncoiled air connection in platform: 3/8" NPT
- Lift requires a clean, dry air supply (50 scfm @ 90 psi with a 40°F dew point)
- Fixed hand control with E-Stop
- Base control to raise and lower platform

## TRAVEL SPEEDS

- Z-Axis (up/down): 15 fpm



Model LPSMT (Manually Positioned Scissor Lifts)					
Model	Raised Floor Ht.	Lowered Floor Ht.	Max Work Ht.	Overall Length	Overall Width
LPSMT-48	4'-4"	13.5"	10'-4"	8'-2"	3'-10"
LPSMT-96	7'-11"	1'-7"	13'-11"		
LPSMT-144	11'-11"	1'-9"	17'-11"		

-For use on hard, flat and level surface  
 -All LPSMT units must be securely fastened to the floor  
 -Designed in accordance with applicable ANSI requirements based on machine configuration as originally manufactured for intended applications

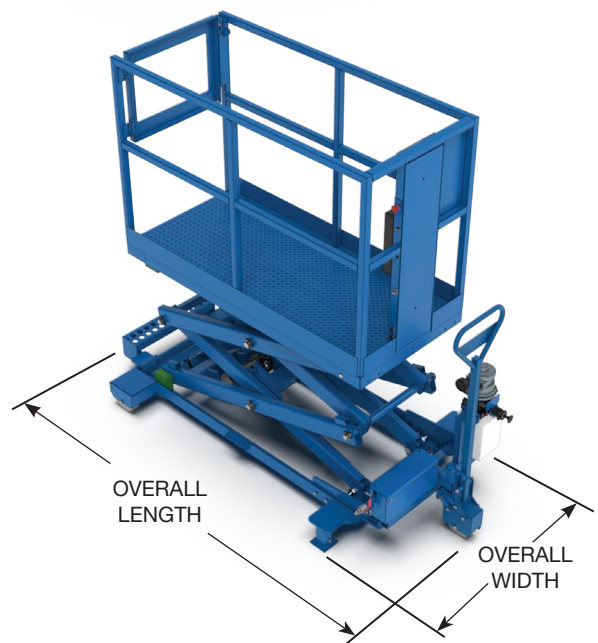

Dimensions shown are nominal. Actual dimensions may vary and are presented with engineering drawings.

Due to continuous product improvement, LPI, Inc. reserves the right to make equipment/specification changes without prior notification.

# Rail Guided Lift Systems LPST

Rail Guided Lifts (LPST) are designed for use where a work process is performed along a fixed linear work area. Ideal for areas with limited floor space. Minimal installation requirements with many lift options available.

## GENERAL INFO

- Raised platform height: 4'-5" to 12'
- Minimum lowered platform height: 14.5"
- Operator Platform Capacity: 500 lbs.
- Platform Dimensions: 66"L x 30"W
- 43.5" high guard rail with self-closing gate
- Pneumatic/Hydraulic power for hazardous areas
- Electric/Hydraulic power for non-hazardous areas
- Filter/Regulator/Lubricator (pneumatic option only)
- Quick and easy connection to air source

## CONTROLS / CONNECTIONS

- Primary air source connection: 1/2" NPT
- Auxiliary unooled air connection in platform: 3/8" NPT
- Lift requires a clean, dry air supply  
(50 scfm @ 90 psi with a 40°F dew point)
- Fixed hand control with E-Stop
- Base control to raise and lower platform
- Optional pendant foot control to raise/lower platform

## TRAVEL SPEEDS

- X-Axis (left/right): Variable up to 40 fpm
- Z-Axis (up/down): 15 fpm

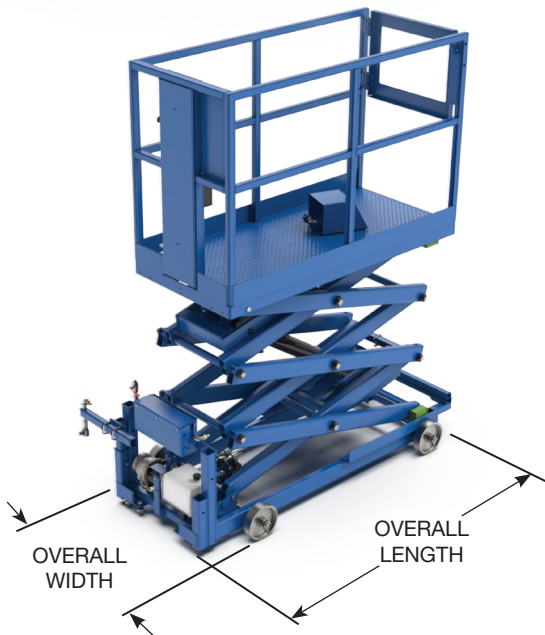
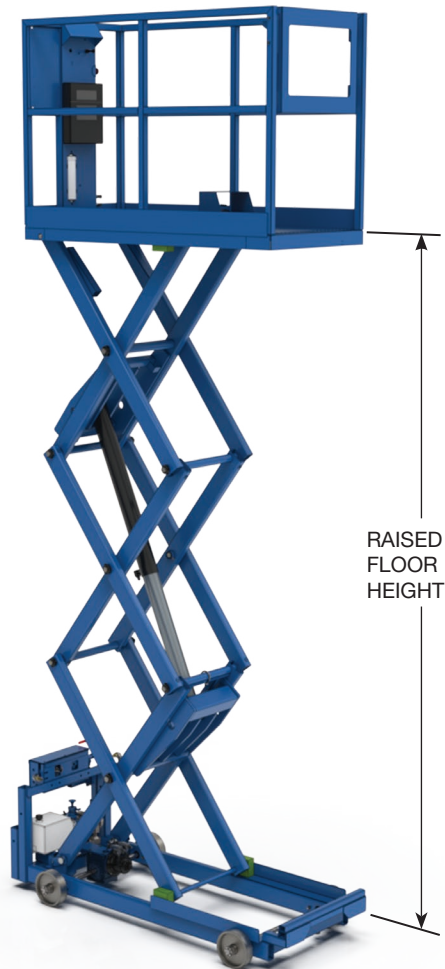

Model LPST (Rail Guided Lift Systems)					
Model	Raised Floor Ht.	Lowered Floor Ht.	Max Work Ht.	Overall Length	Overall Width
LPST-48	4'-5"	1'-2.5"	10'-5"	6'-8"	3'-3"
LPST-96	8'	1'-10"	14'		
LPST-144	12'	2'	18'		

-Slab type machines should only be raised on a hard, flat and level surface  
 -Designed in accordance with applicable ANSI requirements based on machine configuration as originally manufactured for intended applications



Dimensions shown are nominal. Actual dimensions may vary and are presented with engineering drawings.

Due to continuous product improvement, LPI, Inc. reserves the right to make equipment/specification changes without prior notification.

# Rail Guided Lift Systems TK

Rail Guided Lifts (TK) are similar to LPST models, but feature longer and wider platforms and higher load capacities. Designed for use where a work process is performed along a fixed linear work area. Platform size and capacity make this a versatile lift system for applications in fabrication, assembly and maintenance pit areas. Platform can be modified with roll-outs and entry gate options.

## GENERAL INFO

- Raised platform height: 1'-6" to 7'
- Minimum lowered platform height: 18"
- Operator Platform Capacity: 1,000 lbs.
- Platform Dimensions: 120"L x 41"W
- 43.5" high guard rail with self-closing gate
- Pneumatic/Hydraulic power for hazardous areas
- Electric/Hydraulic power for non-hazardous areas
- Filter/Regulator/Lubricator (pneumatic option only)
- Self-closing, self-latching entry gate

## CONTROLS / CONNECTIONS

- Primary air source connection: 1/2" NPT
- Auxiliary uncoiled air connection in platform: 3/8" NPT
- Lift requires a clean, dry air supply  
(50 scfm @ 90 psi with a 40°F dew point)
- Fixed hand controls for X-Axis & Z-Axis travel
- Emergency stop
- Base control to raise and lower platform
- Optional pendant foot control to raise/lower platform

## TRAVEL SPEEDS

- X-Axis (left/right): 40 fpm
- Z-Axis (up/down): 15 fpm

Model TK (Rail Guided Lift Systems)					
Model	Raised Floor Ht.	Lowered Floor Ht.	Max Work Ht.	Overall Length	Overall Width
TK	7'	1'-6"	13'	11'-7"	3'-5"
-Slab type machines should only be raised on a hard, flat and level surface -Designed in accordance with applicable ANSI requirements based on machine configuration as originally manufactured for intended applications					

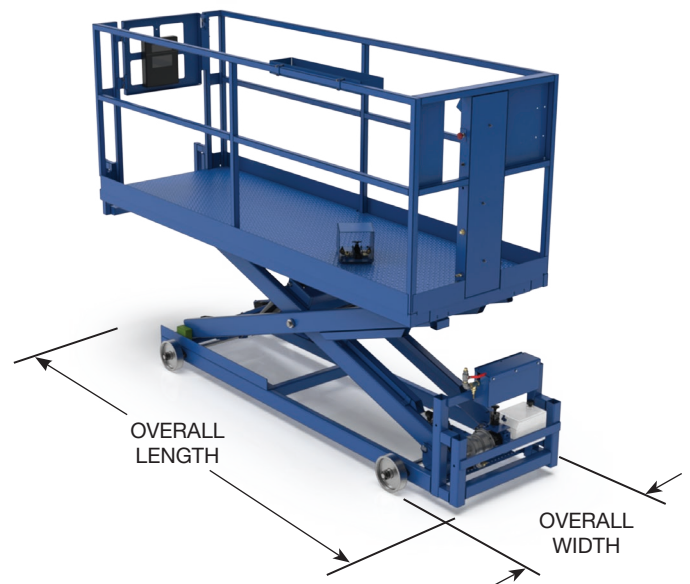
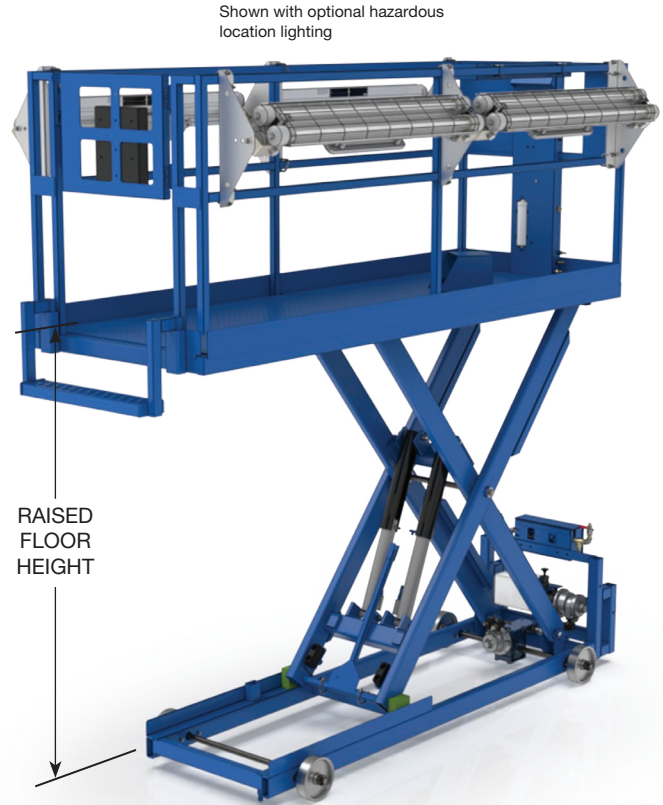

Dimensions shown are nominal. Actual dimensions may vary and are presented with engineering drawings.

Due to continuous product improvement, LPI, Inc. reserves the right to make equipment/specification changes without prior notification.

# Installation Kits LPST & TK Models

LPI offers several design and custom configurations for installation kits. Most installation kits utilize a floor mounted guide rail and either an overhead track and trolley system or wall mounted or lift mounted hose reel. For Paint process applications, an overhead system is recommended to keep hoses off the floor.

## Standard Installation Kits Include:

- Lower Guide Rail (2" x 2" x 1/4" steel tube, pre-drilled for concrete anchors)
- Concrete anchors for securing guide rail
- Rail stops for the ends of lift travel
- Main air line assembly including main air hose, NPT couplers, strain relief, and hose clamps
- Hose reel festooning kit includes a self-retracting hose reel for the main air supply line
- Overhead festooning kit includes festooning track for mounting to ceiling or wall and hose trolleys/carriers

## Standard Festooning Options

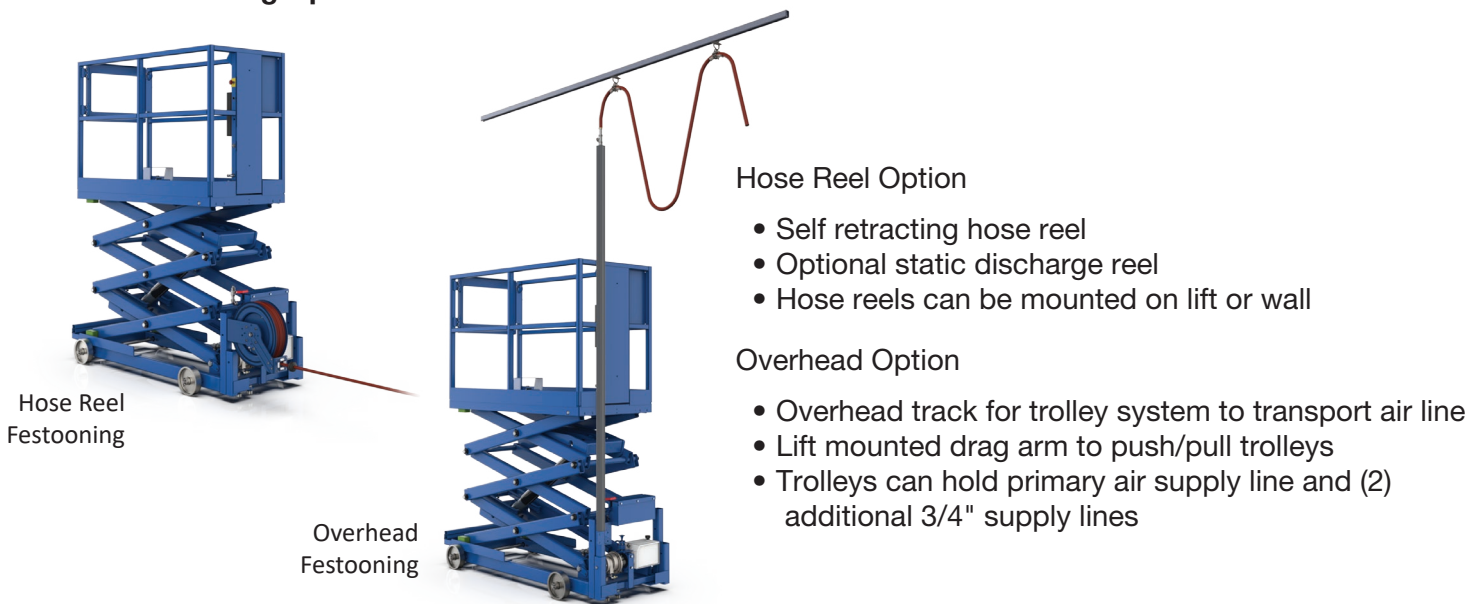

## Guide Rail Options

### Standard Guide Rail Mounting



Surface Mounted

### Optional Guide Rail Mounting configurations

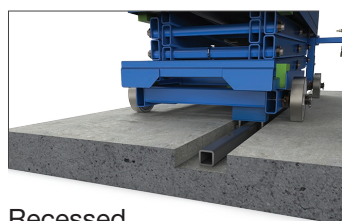

Recessed

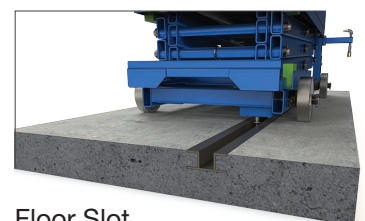

Floor Slot

- Mounting plates, anchoring tabs or spacers (to elevate rail for drainage)
- Optional bumper and end rail stops
- In floor guide or recessed channel for lower guide rail (consult LPI for options and included material)
- Rail shape/material may change depending on customer or application requirements
- Anti-tip rails are available for custom applications that incorporate tip-down or roll-out extensions

LPI service technicians are available to assist with equipment installation. Contact LPI for more information.

Dimensions shown are nominal. Actual dimensions may vary and are presented with engineering drawings.

Due to continuous product improvement, LPI, Inc. reserves the right to make equipment/specification changes without prior notification.



# Work/Catch Platforms LPSPH

The LPSPH (Work/Catch) platform is a versatile and easily customized lift system with adjustable length platform. With roll-outs on each end, the platform can be expanded from 10'-3" retracted, to 16'-6" fully expanded. The starting height of the platform can be adjusted up or down to allow for positioning the lift over obstacles.

## GENERAL INFO

- Raised floor height: Up to 10'-3"
- Minimum lowered platform height\*: 2'-3" +9" adjustment (\*dependent on straddle base option)
- Operator Platform Capacity: 1,500 lbs.
- Roll-Out Capacity: 300 lbs.
- Platform Length: 10'-3" (extendable to 16'-6")
- Platform Width: 35" (roll-outs 30")
- 4" high guard rail with self-closing gate
- Pneumatic/Hydraulic power for hazardous areas
- Electric/Hydraulic power for non-hazardous areas
- Filter/Regulator/Lubricator (pneumatic option only)
- Primary air connection & shut-off on lift base
- Quick and easy connection to air source
- Locking swivel casters
- Adjustable height legs (for positioning lift over products or fixtures)
- Platform can be modified for size & entry gate location

## CONTROLS / CONNECTIONS

- Primary air source connection: 1/2" NPT
- Auxiliary uncoiled air connection in platform: 3/8" NPT
- Lift requires a clean, dry air supply (50 scfm @ 90 psi with a 40°F dew point)
- Fixed hand control with Emergency stop
- Base control to raise and lower platform

## TRAVEL SPEEDS

- Z-Axis (up/down): 12 to 15 fpm

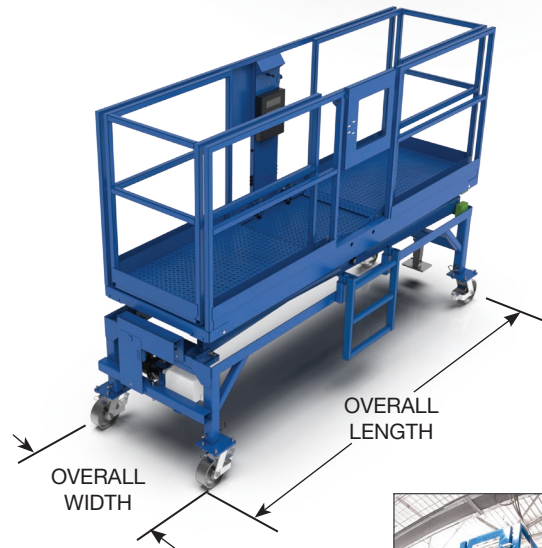

Model LPSPH (Work/Catch Platforms)					
Model	Raised Floor Ht.	Lowered Floor Ht.	Max Work Ht.	Overall Length	Overall Width
LPSPH35123120	10'-3"	2'-6"	~18'-9"	10'-3"	3'-4"
-Slab type machines should only be raised on a hard, flat and level surface -Designed in accordance with applicable ANSI requirements based on machine configuration as originally manufactured for intended applications					

Dimensions shown are nominal. Actual dimensions may vary and are presented with engineering drawings.

Due to continuous product improvement, LPI, Inc. reserves the right to make equipment/specification changes without prior notification.

# Work/Catch Platforms BOOST®

The BOOST® is a versatile self-propelled pneumatic elevating work platform. The BOOST® lift provides maneuverability, ergonomic positioning and added safety for the operator in hazardous environments where combustible dusts or vapors may be present.

## GENERAL INFO

- Hose reel with up to 30 ft. operational travel distance
- Raised platform height: Up to 10'
- Minimum lowered platform height: 2'
- Single Operator Platform Capacity: 300 lbs.
- Platform Length x Width: 2' x 2'
- 43.5" high guard rail
- Pneumatic/Hydraulic power for hazardous areas
- Filter/Regulator/Lubricator
- Quick and easy connection to air source
- Front swivel casters

## CONTROLS / CONNECTIONS

- Primary air source connection: 1/2" NPT
- Auxiliary uncoiled air connection in platform: 3/8" NPT
- Lift requires a clean, dry air supply (40 scfm @ 90 psi with a 40°F dew point)
- Fixed hand control with Emergency stop
- Base control to raise and lower platform

## TRAVEL SPEEDS

- X-Axis (left/right): 40 fpm
- Z-Axis (up/down): 22 fpm

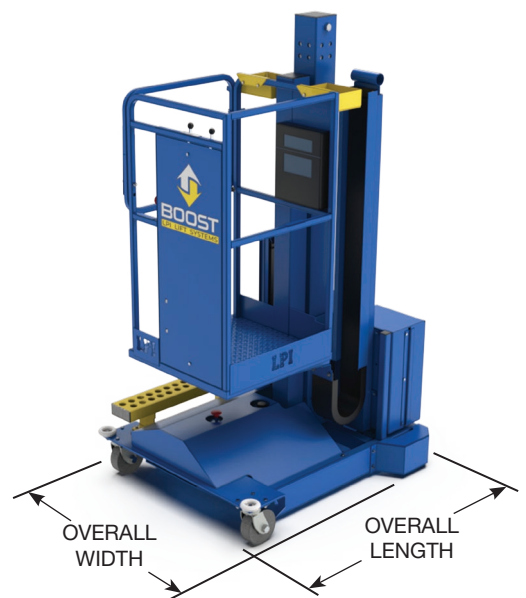
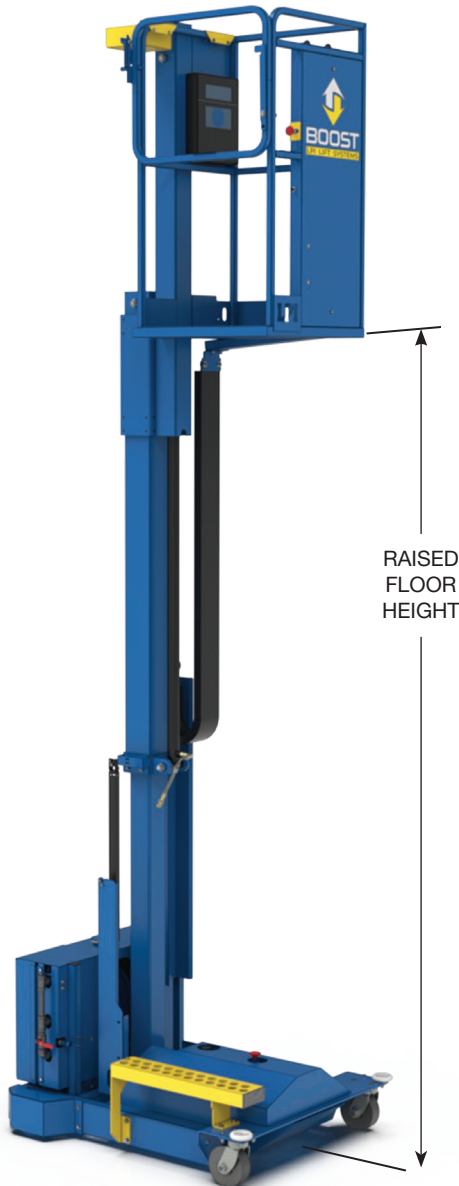

Model BOOST (Elevating Work Platform)					
Model	Raised Floor Ht.	Lowered Floor Ht.	Max Work Ht.	Overall Length	Overall Width
BOOST	10'	2'	16'	4'-5"	3'-2"
-Slab type machines should only be raised on a hard, flat and level surface -Designed in accordance with applicable ANSI requirements based on machine configuration as originally manufactured for intended applications					

Dimensions shown are nominal. Actual dimensions may vary and are presented with engineering drawings.

Due to continuous product improvement, LPI, Inc. reserves the right to make equipment/specification changes without prior notification.

# Work/Catch Platforms BOOST®

## APPLICATIONS

The BOOST® single operator lift is designed for use in hazardous or industrial areas where access is needed at elevated heights.

- Paint Booths
- Paint Prep Areas
- Paint Kitchens
- Sanding/Buffering Areas
- Assembly
- Welding
- Maintenance
- Masking/Decal

## BOOST Features / Options

1. Hose reel & 1/2" hose for 30 ft. operational travel
2. Hand controls for horizontal & vertical travel
3. Auxiliary uncoiled air supply connection in platform
4. Filter/Regulator/Lubricator with main air shut-off
5. Fork lift pockets for distance transport
6. Auxiliary air regulator\*
7. Platform front tool tray\*
8. Static discharge ground reel\*
9. Base mounted tool tray\*
10. Paint pot carrier\* (paint pot not included)
11. 360° swivel air connection kit\*
12. Wide wheel drive kit for floor grating\*
13. Paint gun hook kit\*

\* Optional

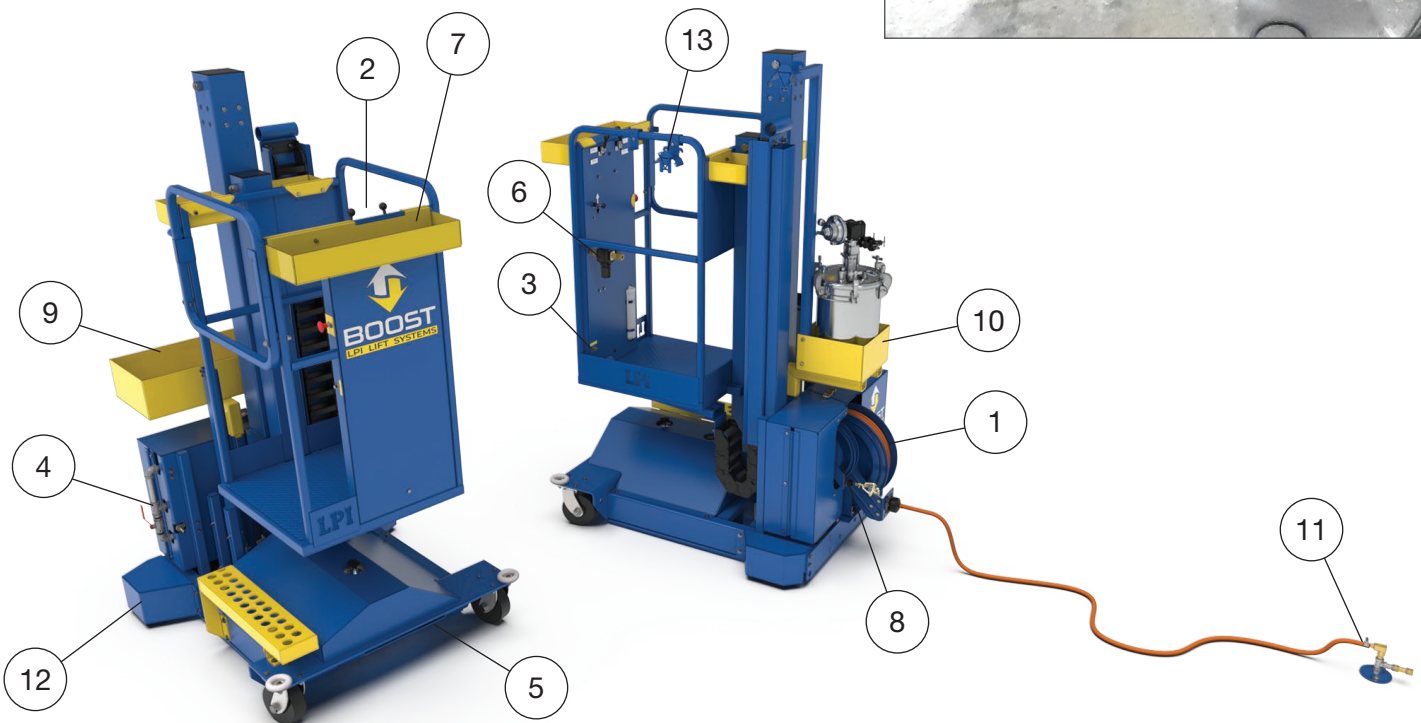
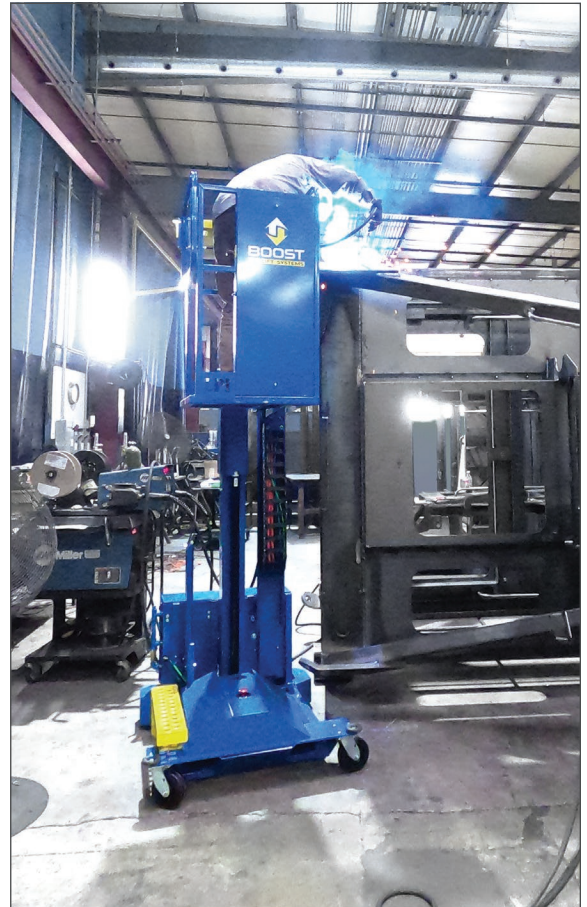

Dimensions shown are nominal. Actual dimensions may vary and are presented with engineering drawings.

Due to continuous product improvement, LPI, Inc. reserves the right to make equipment/specification changes without prior notification.

# Standard & Custom Lift Options

## STANDARD LIFT OPTIONS

Lift Systems and Platforms may be configured in a variety of ways to meet your application needs. Below are some examples of available options that can be incorporated into various lift and platform models.

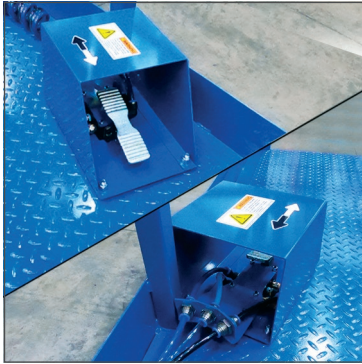

Foot Controls for Horizontal or Vertical Travel



Electric/Hydraulic Power Unit



Accordion Skirts / Bellows



Platform Rollouts / Extensions



Remote Power Unit and Pedestal Controls



Alternative Entry Gates



Full Floor Grating



Specialty Paint Colors / Types



Explosion proof Lighting

Dimensions shown are nominal. Actual dimensions may vary and are presented with engineering drawings.

Due to continuous product improvement, LPI, Inc. reserves the right to make equipment/specification changes without prior notification.

## TYPICAL APPLICATIONS

- Paint / Powder / Coating Processes
- Blast Booth / Room (Stripping & Surface Prep)
- Welding / Fabrication / Assembly
- Wash & Mask (prep)
- Maintenance / Inspection
- Material Handling / Loading Bays
- Clean Rooms
- Hazardous / General Industrial Environments

## COMMON INDUSTRIES SERVED

- Aircraft & Aerospace
- Agricultural & Construction Equipment
- Electrical Power & Distribution
- Mass Transit Manufacturing / Maintenance
- Military Equipment
- Rail Car / Locomotive Manufacturing & Maintenance
- Rail Systems & Equipment
- Transit Authorities
- Trucks / Trailers / Recreational Vehicles
- Modular Home Construction / Prefab Facilities



Dimensions shown are nominal. Actual dimensions may vary and are presented with engineering drawings.

Due to continuous product improvement, LPI, Inc. reserves the right to make equipment/specification changes without prior notification.

# OTHER LPI PRODUCTS

## MULTI-AXIS LIFTS FOR PAINT, BLAST OR POWDER APPLICATIONS



3-Axis Blast (BL)



3-Axis Paint (LP2)



3-Axis Enclosed Blast (EBL)



3-Axis Decal (LP2)



3-Axis Extended Reach Blast (BL)



3-Axis Extended Reach Blast (BL)



3-Axis (LP2)



1-Axis Powder (BL)

## CUSTOM LIFTS

LPI offers standard and custom designed lift solutions that are designed and built to specifically address your application needs. Custom lifts can be designed to accommodate multiple personnel, process equipment or utilities and platform configurations to fit unique environments. Lift systems can be designed to fit any application from a small one person lift to large, high capacity systems.



Custom Rail-Guided Work Platform with Roll-Out Extensions



Overhead Lift System with Drop-Down Platform

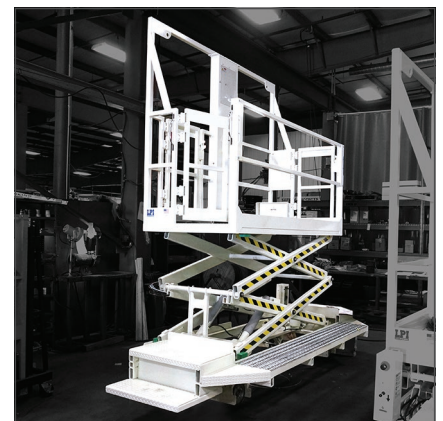

Custom Track Guided Assembly / Inspection Lift

# WARRANTY & SERVICES

## STANDARD SERVICES & MAINTENANCE

LPI, Inc. prides itself on excellent customer service. Our sales, engineering and customer service staff actively ensure our customers are taken care of from initial contact through the project build, delivery and installation. LPI also offers maintenance, training and service support to ensure proper safe operation after installation and throughout the entire product life cycle.

### WARRANTY

LPI is known for its quality, robust designs and we stand behind our products. LPI offers a 12 month warranty on materials and workmanship from the date the order is shipped. For full warranty details, scan the QR code or visit: <https://www.lpi-inc.com/warranty>



### INSTALLATION & TRAINING

LPI offers trained technicians to help guide and assist in the installation of lifts. Consult with a member of the sales team to discuss what level of installation or training assistance would be needed for your application.



### SERVICE / MAINTENANCE / PARTS

Properly maintained LPI lifts provide many years of reliable service. Delayed or neglected maintenance can reduce the life of components and affect the performance of the lift leading to failures and operational downtime. LPI's Service Technicians offer annual inspections and on site maintenance service plans and training to help ensure your lift equipment is running at peak performance.

LPI has many plans and services available that may best suit your needs.

- Scheduled maintenance plans
- Annual on-site safety inspections
- On-site repair / rebuild services
- Operator training
- Replacement parts



To schedule service, maintenance, installation or training, please email our Customer Service department:

[customerservice@lpi-inc.com](mailto:customerservice@lpi-inc.com)



Eau Claire, WI USA  
(800) 657.6956  
[www.lpi-inc.com](http://www.lpi-inc.com)  
[sales@lpi-inc.com](mailto:sales@lpi-inc.com)

# Challenge us with your application!

Request a quote:

Email us at: [quotes@lpi-inc.com](mailto:quotes@lpi-inc.com)

Visit our YouTube channel:

<https://www.youtube.com/user/LPIincLiftSystems>



LPI YouTube channel

LPI® promotes a safe and ergonomic work environment which increases worker productivity. Specifications may be changed subsequent to printing.

No part of this information may be reproduced in whole or part without written permission.

