

STANDARD 3-AXIS LP2

PAINT / WASH

Designed to enhance the productivity and ergonomics for operators. The pneumatically powered lifts are an ideal accessory in hazardous environments and many other manufacturing process or production areas.



Option Package Available
for use in **High Solids Paint
Applications**

GENERAL INFO

- Raised platform height: Up to 22'
- Retracted dimension: 3' (minimum)
- Extended dimension: 8' or 10' (per model)
- Operator platform capacity: 500 lbs.
- Pneumatic/mechanical power unit
- Includes in-line Filter/Regulator/Lubricator
- Standard platform: 48" wide x 21" deep
- Self-closing/self-latching entry gates
- 1-Axis & 2-Axis models available

CONTROLS / CONNECTIONS

- Operator controls on front rail of platform
- Hand controls for Y-Axis, Z-Axis, & E-stop
- Foot control for X-Axis
- Base control to raise and lower platform
- Auxiliary uncoiled air connection in platform
- Lift requires a clean, dry air supply
(80 scfm @ 100 psi with a 40°F dew point)

TRAVEL SPEEDS

- X-Axis (left/right): Variable up to 40 fpm
- Y-Axis (in/out): 15 fpm
- Z-Axis (up/down): 15 fpm

Due to continuous product improvement, LPI, Inc. reserves the right to make equipment/specification changes without prior notification.



3-AXIS LP2

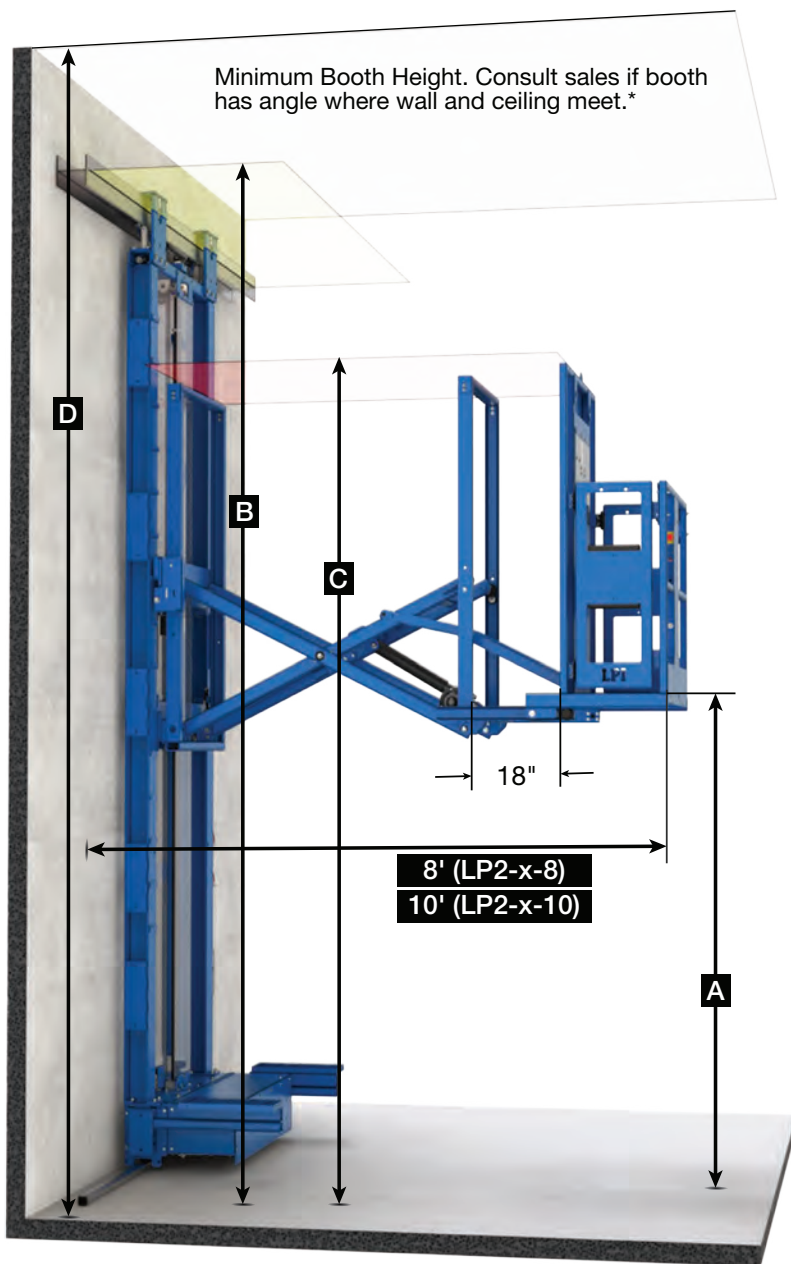

Model Numbering

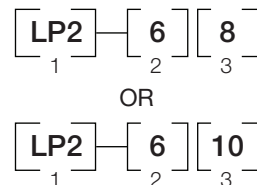

1. Lift Series
2. Raised Platform Height: 6' to 22'
3. Fully Extended: 8' or 10' with 18" roll-out

Model LP2 (Standard Reach)

Model	A	B	C	D
LP2-610	6'	9'-3"	11'-6"	12'
LP2-710	7'	10'-3"	12'-6"	13'
LP2-810	8'	11'-3"	13'-6"	14'
LP2-910	9'	12'-3"	14'-6"	15'
LP2-1010	10'	13'-3"	15'-6"	16'
LP2-1110	11'	14'-3"	16'-6"	17'
LP2-1210	12'	15'-3"	17'-6"	18'
LP2-1310	13'	16'-3"	18'-6"	19'
LP2-1410	14'	17'-3"	19'-6"	20'
LP2-1510	15'	18'-3"	20'-6"	21'
LP2-1610	16'	19'-3"	21'-6"	22'
LP2-1710	17'	20'-3"	22'-6"	23'
LP2-1810	18'	21'-3"	23'-6"	24'
LP2-1910	19'	22'-3"	24'-6"	25'
LP2-2010	20'	23'-3"	25'-6"	26'
LP2-2110	21'	24'-3"	26'-6"	27'
LP2-2210	22'	25'-3"	27'-6"	28'

- A: Raised Platform Height
- B: Centerline of Upper Rail
- C: Overall Max. Lift Height
- D: Min. Booth Height*

Dimensions shown are nominal. Actual dimensions may vary and are presented with engineering drawings.

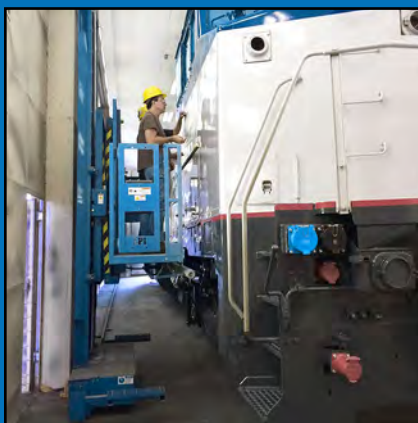

LP2 STANDARD OPTIONS

STANDARD & EXTENDED REACH MODELS



Side Draft
Rear Mast Cover



Flex
Track



Paint Pot Carrier
Single or Double

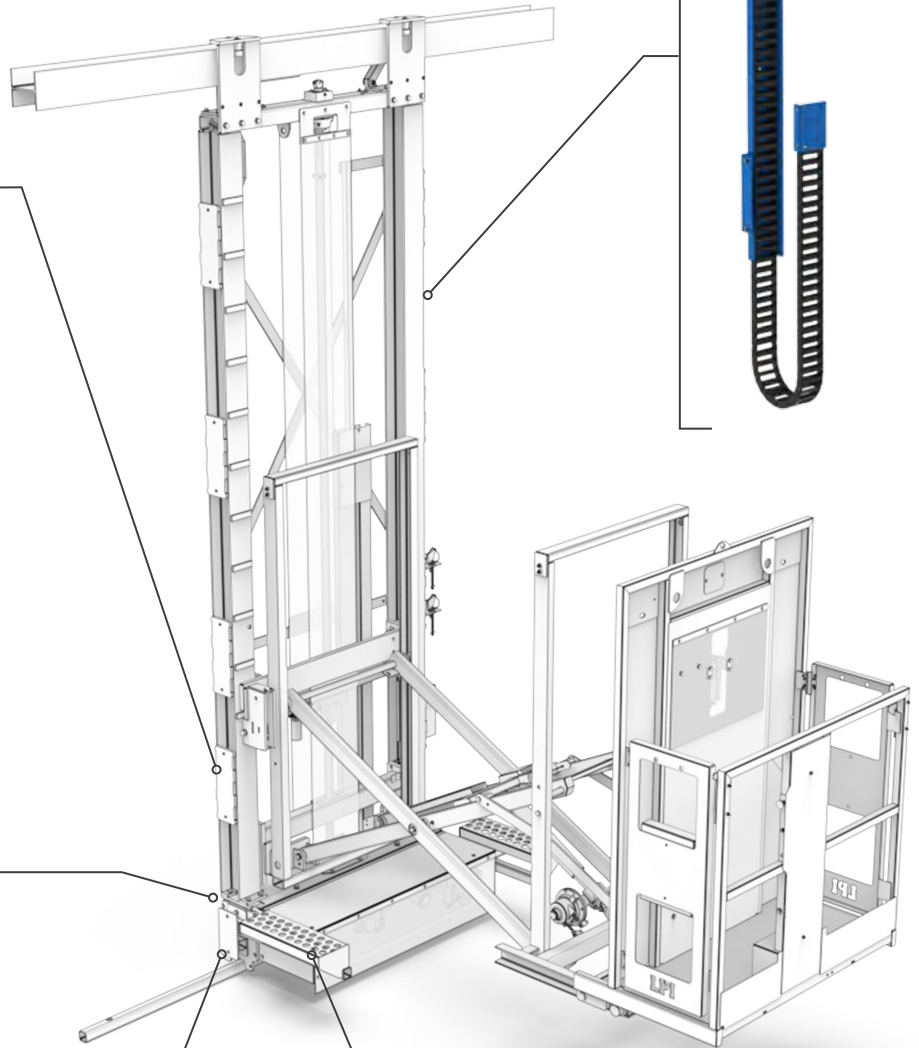

Rail
Scraper



Double Step

Additional options available.

Consult with LPI sales
about all options available
or custom solutions to fit
your application.

LP2 STANDARD OPTIONS

STANDARD & EXTENDED REACH MODELS

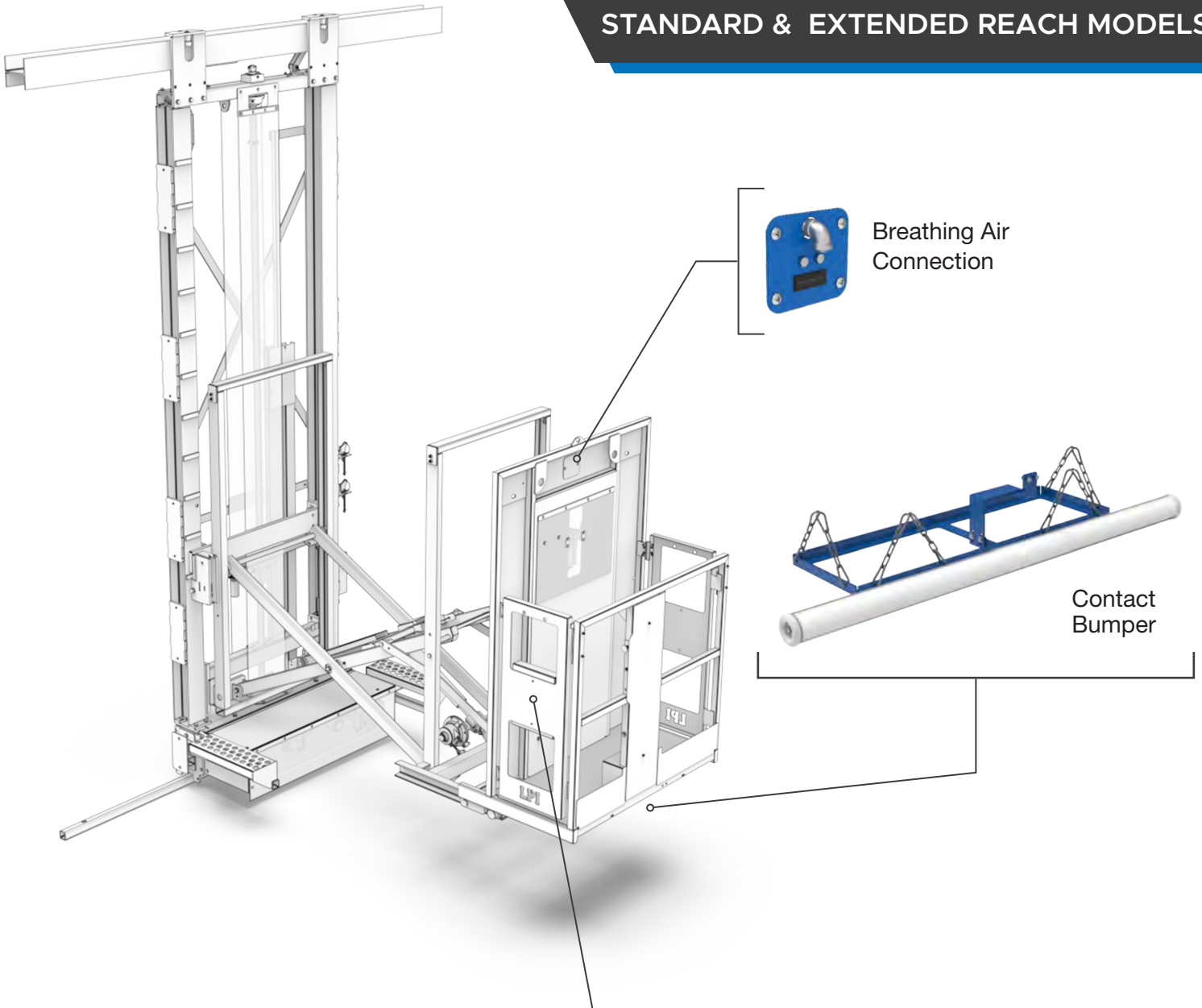

Platform Depth Sizes:
21" / 24" / 27" / 30" / Custom



Front Gate



Tip-Out Front Rail